

Classroom Activity

Origami Bookmaking

Enduring Understanding Artists and authors use sketchbooks to record observations and ideas.

Grades K–2

Time One class period

Art Concepts Line, shape, form, paper-folding techniques

Literacy Concepts Describing, questioning, expressing likes and understandings

Materials Heavy cardstock (8 ½ x 11 in.), regular paper (8 x 10 ½ in.), origami paper (3 ½ in. & 4 ½ in. squares), stretchy cord, colored pencils, and glue sticks

Talking about Art View and discuss the printed image of *Seated Dog* (late 17th century).

What do you see? What do you know about this artwork? This artwork represents a dog, and dogs are happy and playful animals. Think of a dog that you have met before. Describe the dog's characteristics and actions. Dogs are curious and excited. They like to run, jump, and explore new things. How would you describe the artwork *Seated Dog*? This dog is happy because he is smiling. His curvy tail says that he is curious. His front paws look as if he is ready to pounce.

What do you wonder about this artwork? Questions about this work might include, "Is this artwork old or new?," "How was this artwork made?," and "Why did the artist give the dog colored spots?" This artwork was probably made in the year 1680. It was created using a special clay called porcelain. First, the artist studied the 2D lines and shapes of the dog (curvy, straight, or wiggly) then captured the 3D form of the dog in a clay. Next, the artist painted the clay form in a clear glaze and fired (or baked) the clay in a kiln (or oven). After the clay hardened and cooled, the artist painted the dog's spots in colored enamel and fired the form again. The painted spots suggest that this dog might be a Dalmatian, and the artist's choice of colors give the Dalmatian an imaginative look.

Making Art

Transform simple paper into a 3D animal form using origami (or paper-folding) techniques. First, create a book by folding a sheet of cardstock in half. Select four to five sheets of regular paper to serve as the inside pages. Lay the pages on top of each other, fold the sheets in half, and insert the pages into the book cover. Open the book to the center page. Measure a 17.5 in.-long piece of stretchy chord. Pull the two chord ends together and tie in an overhand knot. Wrap the circular stretchy cord around the book's center fold to create the binding.

Next, create an origami dog to decorate the book cover. Select a $3\frac{1}{2}$ in. square origami sheet. Use the following steps to create the head:

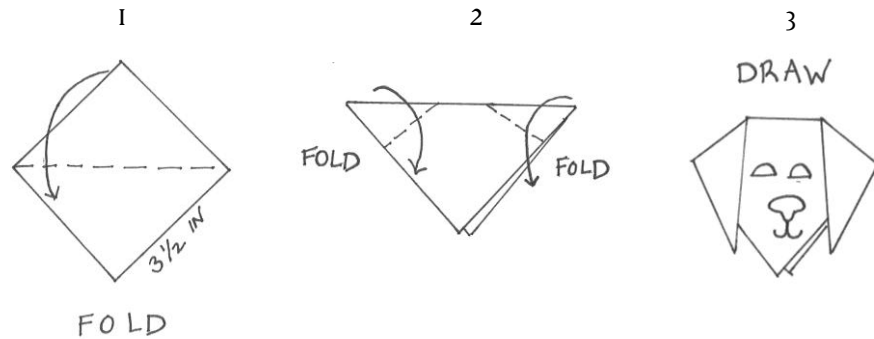

Then, select a $4\frac{1}{2}$ in. square origami sheet. Use the following steps to create the body. Glue the head and body together, and adhere to the cover of the book:

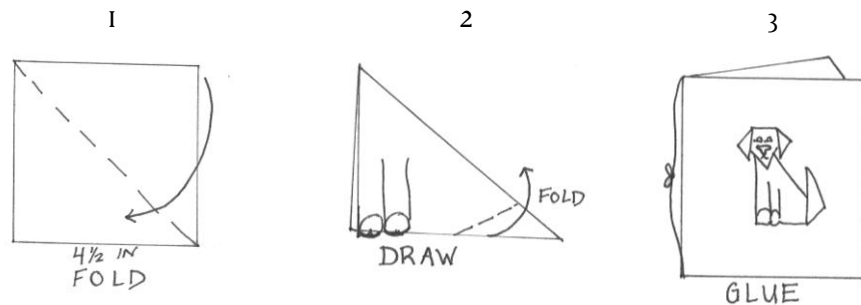

Reflection

What do you like about this artwork and why? What did you learn about this artwork? Artists find inspiration in nature and in animals. Artists incorporate adjectives and actions into their animal works. Animal artworks can look realistic and imaginative. Simple 2D materials can be transformed into 3D animal forms.

Curriculum Connection

Compare this dog with other dogs from LACMA's permanent collection, or select complementary literary texts, such as books about dog, cat, or bird characters. Ask students to record their findings about animal artworks and stories in their origami books. Students can chart learning and progress by returning to these questions, "What I know about this artwork (or book)," "What I wonder about this artwork (or book)," and "What I learned about this artwork (or book)."

For a classroom worksheet related to this activity, as well as a selection of animal images from LACMA's permanent collection, see "Lesson Plans & Resources" on the curriculum CD.

Describing

Name _____ Date _____

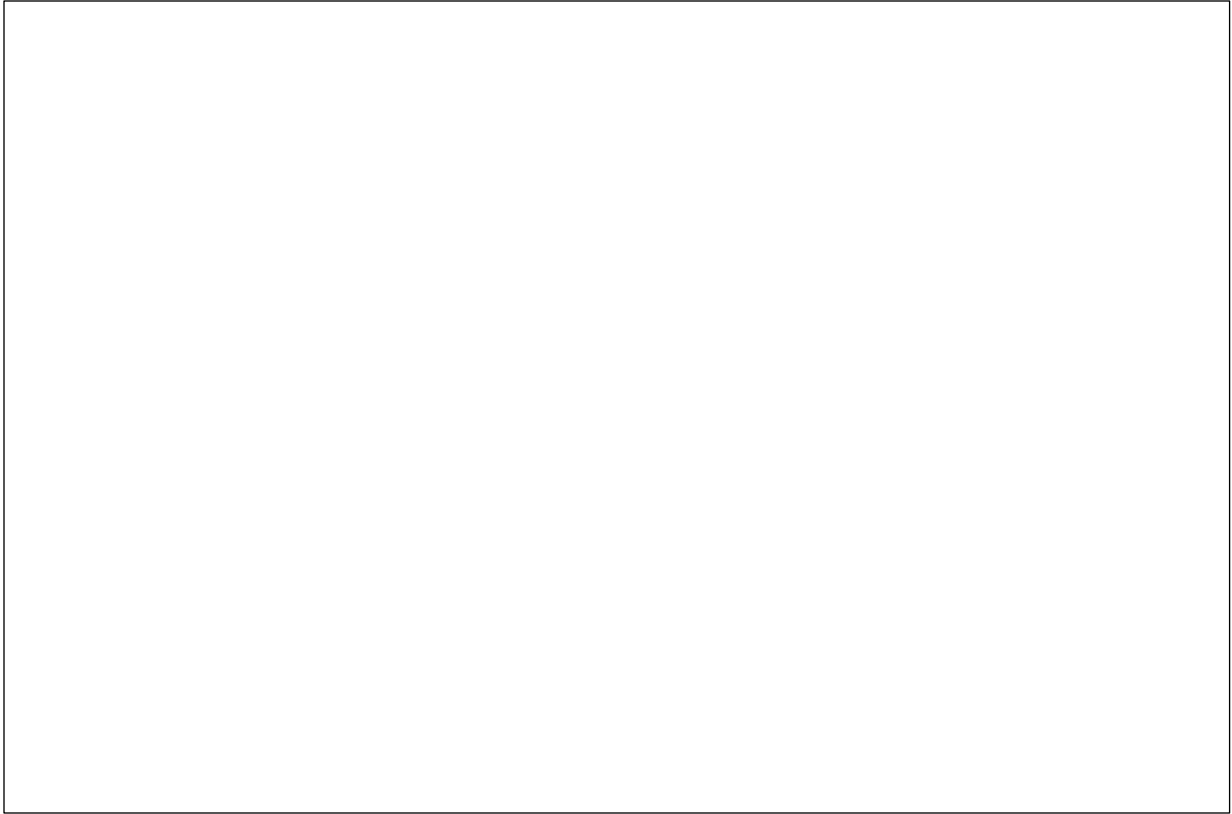

Artwork Title _____ Date _____

What I know about this artwork.

What I wonder about this artwork.

What I learned about this artwork.

DOGS AT LACMA



FOUR JOINED DOGS

Mexico, Nayarit, 200 BC–AD 500
Burnished ceramic with slip; 4 x 5 ½ in.
The Proctor Stafford Collection, purchased
With funds provided by Mr. and Mrs. Allan C. Balch
(M.86.296.72) Photo © Museum Associates/LACMA



BLACK DOG

Yoshitomo Nara, 1999
Fiberglass, high gloss body paint; 44 ½ x 60 x 40 in.
Gift of Peter Norton and Eileen Harris Norton
Santa Monica in honor of the museum's 40th
anniversary (M.2005.137.1) © Yoshitomo Nara
Photo © Museum Associates/LACMA



TOY DOG

Follower of Kenzan, Japan, 19th century
Pottery with colored and crackled glazes
1 5/16 x 1 7/16 x 1 3/16 in.
Raymond and Frances Bushell Collection (M.87.263.64)
Photo © Museum Associates/LACMA



DOG FIGURINE

Egypt, probably modern
Bronze; length: 2 1/16 in., width: 1 9/16 in.
Gift of Carl W. Thomas (M.80.203.75)
Photo © Museum Associates/LACMA

To access images of these artworks, visit:
<http://collections.lacma.org>
and search for works by title or by
acquisition number (ex, M.2005.137.1).

CATS AT LACMA



FIGURINE OF THE GODDESS BASTET AS A CAT
Egypt, 1081–525 BC
Bronze, inlaid gold; 2 $\frac{3}{4}$ x 1 $\frac{3}{16}$ x 1 $\frac{3}{4}$ in.
Gift of Varya and Hans Cohn (AC1992.152.51)
Photo © Museum Associates/LACMA



CAT AND SNAKE
Lizbeth Stewart, 1990
Earthenware, Overall: 37 x 50 x 24 in.
Gift of Helen Drutt, Philadelphia, and the artist in honor of
Lois and Robert Baordman (M.79.176.24) © Lizbeth Stewart
Photo © Museum Associates/LACMA



CAT MAKING-UP
Inagaki Tomoo, 1955
Woodblock print Image: 23 $\frac{5}{8}$ x 1 $\frac{1}{8}$ in.,
Paper: 24 $\frac{1}{2}$ x 18 $\frac{1}{4}$ in. Gift of Mr. and Mrs. Felix Juda
(M.79.176.24) © Estate of Inagaki Tomoo
Photo © Museum Associates/LACMA



UNTITLED
Georg Schrimpf, circa 1919
Woodcut on wove paper; Image: 3 $\frac{3}{8}$ x 4 $\frac{7}{16}$ in.
The Robert Gore Rifkind Center for German Expressionist
Studies, purchased with funds provided by Anna Bing Arnold,
Museum Associates Acquisition Fund, and deaccession funds
(83.1.1634c) Photo © Museum Associates/LACMA

To access images of these artworks, visit:
<http://collections.lacma.org>
and search for works by title or by
acquisition number (ex, M.2005.137.1).

BIRDS AT LACMA



OIL LAMP (SAMAI) IN THE FORM OF A BIRD
India, Deccan, 17th century
Copper alloy; 6 ¼ x 2 ½ x 6 ¾ in.
Gift of John Lawrence Fine Arts (AC1993.152.1)
Photo © Museum Associates/LACMA



BIRD-SHAPED VESSEL WITH SINGLE SPOUT
Peru, South Coast, 100 BC-AD 200
Ceramic, hand built, slip painted,
burnished and fired; 3 ½ x 4 ½ in.
Gift of Nasli M. Heeramanek (M.73.48.21)
Photo © Museum Associates/LACMA



ABSTRACT BIRD
Japan, 19th century
Cryptomeria or cedar wood with inlays
2⁹/₁₆ x 1⁵/₁₆ x 7⁷/₈ in.
Raymond and Frances Bushell Collection (M.87.263.129)
Photo © Museum Associates/LACMA



PAIR OF BIRD ASHTRAYS
Bruce Anderson, 20th century
Stoneware; a) 2 ¼ x 6⁷/₈ x 3 ½ in. b) 3 x 6⁷/₈ x 3⁵/₈ in.
Gift of Roy Rydell in memory of Bruce Anderson (AS1999.4.1a-b)
Photo © Museum Associates/LACMA

To access images of these artworks, visit:
<http://collections.lacma.org>
and search for works by title or by
acquisition number (ex, M.2005.137.1).

Classroom Activity

Collage Storytelling

Enduring Understanding Just as authors use words to compose sentences, artists use the elements of art to compose images.

Grades 3–5

Time One to two class periods

Art Concepts Line, shape, color, horizon, composition, character, action, setting

Literacy Concepts Identifying, retelling, sequencing, planning and predicting

Materials Construction paper, regular paper (large sheets such as 18 x 24 in.), colored pencils, scissors, and gluesticks

Talking about Art View and discuss the printed image of *Structural Study for a Mural (Estudio estructural para mural)* (1921).

What words do you think of when you look at this work of art? Ask students to record thoughts in writing *and* drawing, using words and pictures to describe what they see. Create a classroom word bank by combining students' words, or by ask students to write or draw their words and pictures on the board.

How would you categorize these words? As a group activity, sort the classroom word bank according to predetermined categories, such line, shape, and color. These categories will fold in vocabulary terms related to the elements of art.

LINE	SHAPE	COLOR
Swirly Curvy Straight Zig-zag	Circle Triangle Oval Rectangle	Yellow Brown Blue Black

What story is the artist telling? Conduct a second word bank focused on storytelling and sort the words according to the parts of a story.

CHARACTER	ACTION	SETTING
Woman Girl Baby Mother	Sitting Talking Kneeling Carrying	Flower Leaf Bowl Wallpaper

What might happen next in this story? Imagine that this artwork represents a "Before" scene. What clues did the artist give you to help predict what happens "After?" Ask students to act out different possibilities, using their bodies and movement to create visual predictions. Ask students to plan and chart their predictions according to character, action, and setting.

Making Art

Use collage techniques to test your prediction. First, cut an assortment of lines and shapes out of construction paper, pulling inspiration from the lines and shapes depicted in the artwork. Use a large sheet of paper as the background and draw a horizon line using a colored pencil.

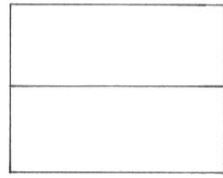

Then, "retell" the scene by arranging and layering the lines and shapes as they appear in the work.

Next, rearrange the lines and shapes. Use the lines and shapes to depict what happens in the next scene.

When you have reached a desired composition, glue the shapes to the background. Lastly, enhance the scene by adding color, words, or captions with colored pencils.

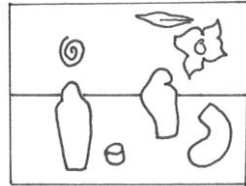

ARRANGE

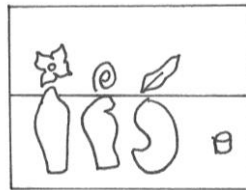

REARRANGE

Reflection

Pair up and share your artwork with a partner. Choose one of your artworks to act out together and write a short sentence to accompany the scene. Share your action and movement with the rest of the class in an art-inspired performance. Ask students to predict the accompanying caption, then reveal your sentence to the class.

Curriculum Connection

Expand on the lesson by incorporating a literary text. Choose one scene from the text. Who are the characters, what action is happening, and where does the setting take place? What clues did the author give you to predict what happens next? Discuss the differential use of written and visual foreshadowing.

For a classroom worksheet related to this activity, see "Lesson Plans & Resources" on the curriculum CD.

Planning & Predicting

Name _____ Date _____

Artwork Title _____ Date _____

ARTIST'S CLUES

WHAT I THINK WILL HAPPEN NEXT

Who are the characters?



What action is happening?



Where is the setting?



Classroom Activity

Painting Perspectives

Enduring Understanding	Artists document life by capturing visual details and sensory experiences of their surroundings.
Grades	6–8
Time	One class period
Art Concepts	Space, perspective, movement, unity
Literacy Concepts	Explaining, inferring, classifying, agreeing and disagreeing
Materials	Paper and pencils
Talking about Art	Take a moment to study the printed image of <i>Angel's Flight</i> (1931).

What do you see? What is happening in this picture? Two women look downhill. They see people climbing steps to reach the hilltop. The area is populated by many people, buildings, and objects. It is an urban area with residential and commercial buildings. The sun peeks over a rooftop, and you can almost hear the noise that fills this space.

What do you see that makes you say that? People are looking at each other. They are standing and sitting in rocking chairs as they converse. One person is emerging from a doorway as if to call out to someone. The people ascending the hill use canes to help them walk.

What more can you find? This painting depicts a 1930s view of *Angel's Flight*, the downtown Los Angeles landmark. Although the artist does not include the railway in the composition, he offers an array of scenic perspectives, including the large Victorian homes and apartments that once populated Bunker Hill.

The above questions form an inquiry-based facilitation approach called Visual Thinking Strategies. "What do you see," or "What is going on in this picture?," encourages close looking. "What do you see that makes you say that?" requires students to ground their observations in the artwork and to use visual evidence to support their claims. "What more can we find?" reminds students that there is always more to look at and talk about in the work of art.

As the facilitator, the educator should paraphrase students' comments to ensure that students are heard and to model proper use of language for the group. Insert vocabulary during the process of paraphrasing to introduce and reinforce terms, concepts, and ideas related to the lesson's objective. As students voice comments, point to the place in the artwork that the students are referring to. By pointing, the content of the comments are anchored in the imagery of the artwork.

Writing about Art

If you were a person in this painting, what would you hear? What would you see, smell, and feel? Try on different roles, evaluate different perspectives, and immerse yourself in the "environment" created by this work of art. Have pairs of students approach this work of art from the viewpoint of a person, an object, or even a building, using the following sentence frames:

"We think the women are feeling ... because ..."
"We think the laundry is thinking ... because ..."
"We think the billboard is saying ... because ..."

Ask students to share their sentences frames with the class by writing them on the board. Have students classify details discovered in the painting using these sentence frames:

"We organized the ... by ..."
"You can group these together because ..."
"... is a part of this group because ..."

Lastly, ask students to respond to their classmates' statements by expressing agreements and disagreements using these sentence frames:

"We agree with ... however ..."
"We disagree with ... however ..."
"We think ... were ... when they said ..."

Reflection

How has your understanding of this artwork changed? Encourage students to synthesize their thinking and identify new understandings by individually responding to these reflection statements:

"I used to think ... but now I think ..."
"The more I think about this artwork, I realize ..."
"I believe the artist is trying to say that ..."

Curriculum Connection

Select an informational text that relates to themes that emerged from *Angel's Flight*, such as articles about population, urbanization, or development. Encourage the transfer of content and critical thinking skills by asking students to compare the artwork with the text. Suggested sentence frames for response may include:

"Based on what I read, I believe ..."
"Even though it does not say so in the text, I think ..."
"I suppose the author is trying to say that ..."

For a classroom worksheet related to this activity, see "Lesson Plans & Resources" on the curriculum CD.

Name _____ Date _____

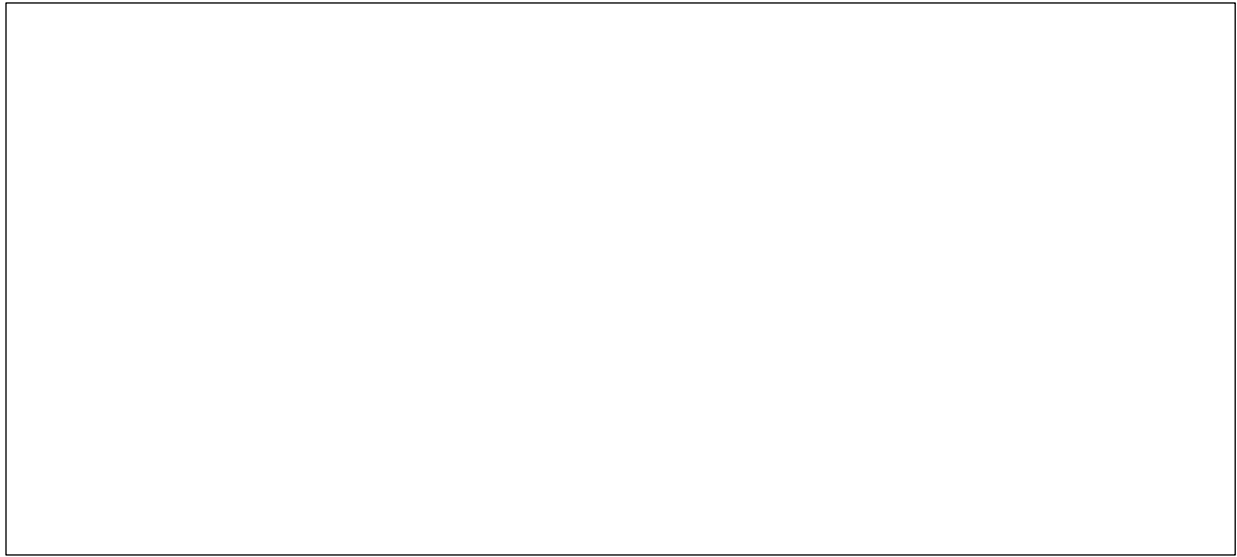

Artwork Title _____ Date _____

EXPLAINING THE SCENE

We think the women are feeling _____ because _____ .

We think the laundry is thinking _____ because _____ .

We think the billboard is saying _____ because _____ .

CLASSIFYING THE DETAILS

We organized the _____ by _____ .

You can group these together because _____ .

_____ is a part of this group because _____ .

AGREEING/DISAGREEING WITH OTHERS

We agree with _____ however _____ .

We disagree with _____ however _____ .

We think _____ were _____ when they said _____ .

Classroom Activity

Summarizing Ideas

Enduring Understanding	One artwork can be filled with a world of ideas.
Grades	9–12
Time	One class period
Art Concepts	Material, technique, inspiration, detail, purpose, time, movement, pattern
Literacy Concepts	Evaluating, summarizing, expressing a position
Materials	Paper and pencils
Writing about Art	Take a moment to study the printed image of <i>Royal Peacock Barge</i> (late 19 th century).

Ask students to select one "art idea" to respond to in writing. Ideas may include: material (what the artwork is made of), technique (how the artwork was made), inspiration (what the artist was thinking), detail (things that describe the artwork), purpose (why the artwork was made), time (when the artwork was made), movement (where your eye goes), and pattern (things that repeat in the artwork). Have students free write about this idea while studying the artwork. They can respond using a combination of drawing and writing. Ideally students should write without stopping for several minutes, focused on their ideas first and not worrying about grammar, spelling, or punctuation.

When finished, ask students to read over what they have written. Next, students should choose one word or phrase that summarizes the ideas that they expressed in their writing. If they included the word or phrase in their writing, they may circle it.

Talking about Art

Divide the class into small working groups. Ask students to share the words that they chose with their group members. They should also provide a brief explanation as to why they chose the word and what makes the word important to their understanding of the artwork. Encourage them to elaborate on the word by sharing additional observations about the artwork.

Take a break and return to the artwork. Spend another moment quietly studying what you see. Now that you have had a second look at the artwork, what do you notice that you did not notice before? Turn back to your group members and discuss the details that went unnoticed, such as the elaborate patterns that adorn the barge, the elephant figures that support the vessel's base, the people conversing under the canopy, or the placement of the barge to evoke movement.

After considering the perspectives of your peers, what new word or phrase summarizes your small group conversation?

Gather as a class and ask a representative from each group to share their new word or phrase. They should also share why they feel the word summarizes the small group's understanding of the artwork.

Reflection

What questions are you left with about this work of art? Questions may arise about the material—ivory. This work speaks to a long and rich history of ivory carving in India. Over the course of its millennia of artistic expression, several natural sources of ivory, antler, and bone have been utilized to create a wide variety of objects.

Why did the artist create a boat? The largest Indian carved-ivory objects—sometimes made from an entire tusk or more—are ivory boats like this one. They were made during the late 19th and early 20th centuries in Murshidabad, the great Bengali center of ivory carving, in what is now northeast India. These celebratory boats were used by the governor of Bengal and his guests during festivals on the Ganges river.

Curriculum Connection

Allow student interests to direct research about this artwork and time period. What were these boats used for? What is the significance of the boat image? What rivers or bodies of water border the country of India? What natural resources are native to this part of the world? Fold in art and social studies vocabulary and concepts to support students' directed research.

For a classroom worksheet related to this activity, see "Lesson Plans & Resources" on the curriculum CD.

